

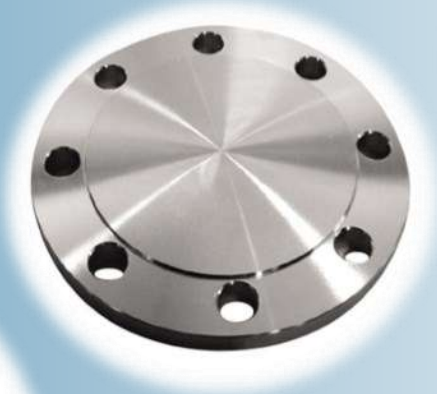

IOCS S.r.L.

Hoses & Ancillaries Equipment Supply for Oil & Gas Industry

FLANGES & STUD BOLTS



- Light Weight Blind Flanges
- Heavy Blind Flanges for Hydro Test
- Towing Lifting Blind Flanges
- Welding Neck & Blind Flanges
- Vacuum Plexiglass Flanges
- Stud Bolts c/w Nuts
- Exagonal Head Bolts c/w Nut

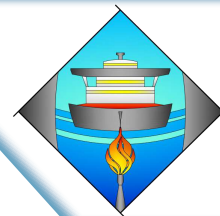

Prod. Code: 010

Light Weight Blind Flanges

Flange ASME B 16.5 Class 150lb

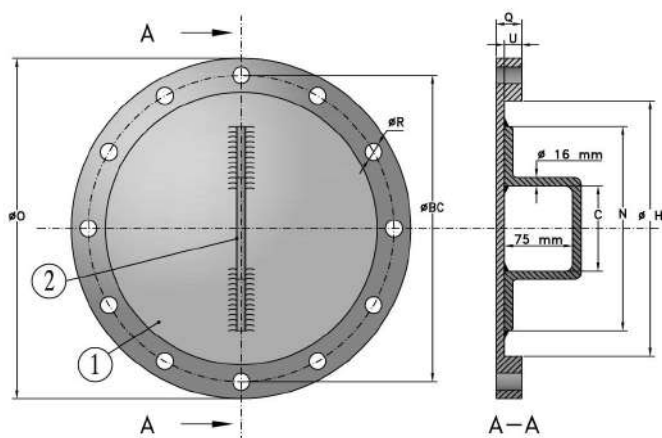

From \varnothing 150 to \varnothing 300

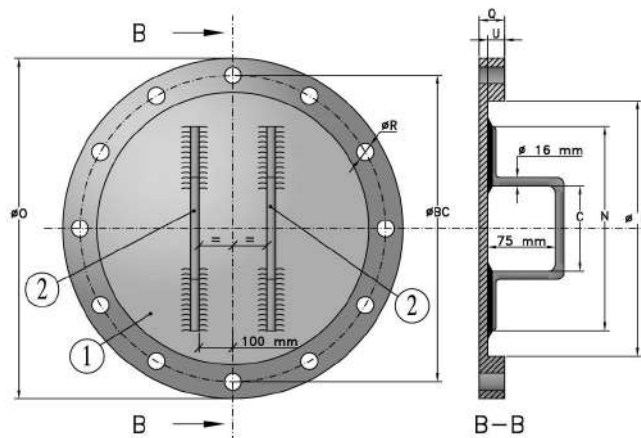

From \varnothing 400 to \varnothing 500



They are used behind the camlock coupling or fitted upon the hose flange. Blind flange is used when the line is towed or is on stand by. The lightweight flange is approximately half the thickness of a standard flange, hence reducing total equipment weight at the end of the hose string and making it easier to handle manually. Lightweight blind flanges should not be used for pressure testing.

Type A blind flange has an outer ring at full ANSI B 16.5 flange thickness for capture by the cams of a camlock coupling.

Type B blind flange is for direct bolting to a Standard flange. They are supplied as Steel finish Hot Deep Galvanized or as Stainless Steel.

DIMENSIONS AND TOLERANCES ACCORDING TO ASME B 16.5 CLASS 150lb

Nominal Diameter (Inch)	\varnothing O (mm)	\varnothing BC (mm)	\varnothing R (mm)	Q (mm)	Holes (N°)	N (mm)	\varnothing H (mm)	U (mm)	C (mm)	Handles (N°)	Weight (Kg)
6"	150	279,4	241,3	22,2	25,4	8	175	197	16,9	125	7
8"	200	342,9	298,4	22,2	28,6	8	220	254	19,1	150	12
10"	250	406,4	361,9	25,4	30,2	12	240	317,4	20,2	150	15
12"	300	482,6	431,8	25,4	31,8	12	260	381	21,2	150	25
16"	400	596,9	539,7	28,6	36,6	16	300	482,5	24,5	150	46
18"	450	635,0	577,8	31,7	39,7	16	320	520,6	26,5	150	60
20"	500	698,5	635,0	31,7	42,9	20	340	571,6	28,6	150	71

Carbon Steel Material

1. ASTM A 105
2. ASTM A 516 or equivalent

Also Available in Aluminium Material

1. Aluminium 6082
2. Aluminium 6082



Light Weight Blind Flanges

Flange ASME B 16.5 Class 300lb

Prod. Code: 011

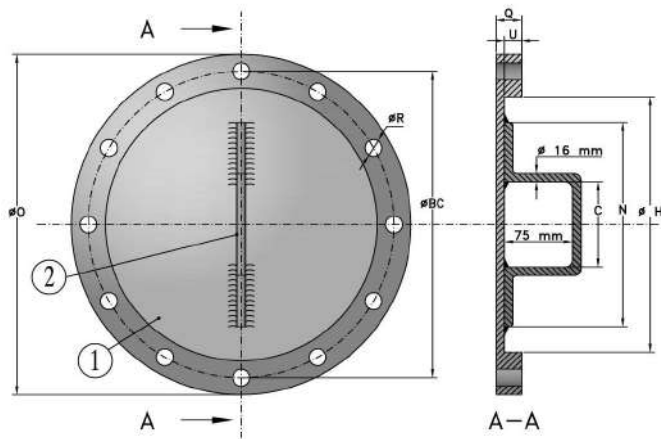

From ϕ 150 to ϕ 300

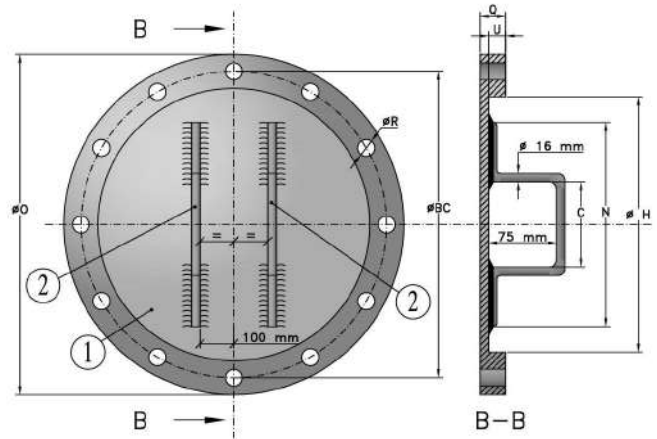

From ϕ 400 to ϕ 500



They are used behind the camlock coupling or fitted upon the hose flange. Blind flange is used when the line is towed or is on stand by. The lightweight flange is approximately half the thickness of a standard flange, hence reducing total equipment weight at the end of the hose string and making it easier to handle manually. Lightweight blind flanges should not be used for pressure testing.

Type A blind flange has an outer ring at full ANSI B 16.5 flange thickness for capture by the cams of a camlock coupling.

Type B blind flange is for direct bolting to a Standard flange. They are supplied as Steel finish Hot Deep Galvanized or as Stainless Steel.

DIMENSIONS AND TOLERANCES ACCORDING TO ASME B 16.5 CLASS 300lb												
Nominal Diameter (Inch)	ϕ O (mm)	ϕ BC (mm)	ϕ R (mm)	Q (mm)	Holes (N°)	N (mm)	ϕ H (mm)	U (mm)	C (mm)	Handles (N°)	Weight (Kg)	
6"	150	317,5	269,9	22,2	36,5	12	175	197	16,9	125	1	N.A.
8"	200	381,0	330,2	25,4	41,3	12	220	254	19,1	150	1	N.A.
10"	250	444,5	387,3	28,6	47,6	16	240	317,4	20,2	150	1	N.A.
12"	300	520,5	450,8	31,7	50,8	16	260	381	21,2	150	1	N.A.
16"	400	647,7	571,5	34,9	57,1	20	300	482,5	24,5	150	2	N.A.
18"	450	711,2	628,6	34,9	60,3	24	320	520,6	26,5	150	2	N.A.
20"	500	774,7	685,8	34,9	63,5	24	340	571,6	28,6	150	2	N.A.

Carbon Steel Material

1. ASTM A 105
2. ASTM A 516 or equivalent

Also Available in Aluminium Material

1. Aluminium 6082
2. Aluminium 6082

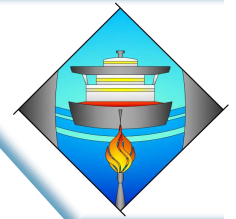

Heavy Blind Flanges

Flange ASME B 16.5 Class 150lb for Hydrostatic Test

Prod. Code: 020

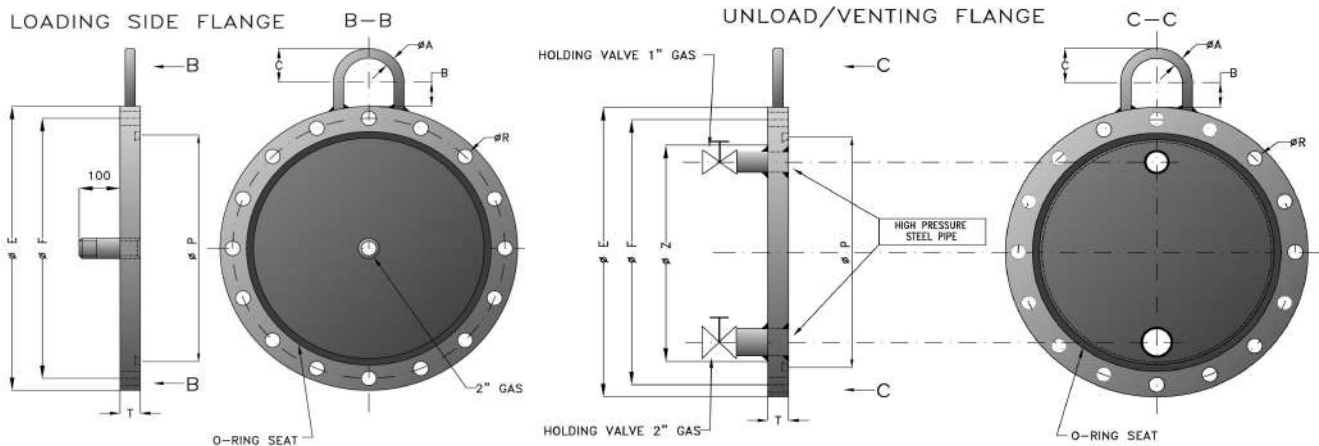

NOMINAL DIAMETER (Inch / mm)		FLANGE DIMENSIONS AND TOLERANCES ACCORDING TO ASME B 16.5 CLASS 150lb					Ø Z (mm) Tol. -5+0	Ø P (mm) Tol. ± 1	LIFTING RING		
		Ø E (mm9)	Ø F (mm)	Ø R (mm)	T (mm)	HOLES (N°)			Ø A (mm) Tol. ± 1	B (mm) Tol. ± 1	C (mm) Tol. ± 1
4"	100	228,6	190,5	19,05	23,8	8	100	138	19	50	50
6"	150	279,4	241,3	22,2	25,4	8	150	195	19	50	50
8"	200	342,9	298,4	22,2	28,6	8	200	247	19	50	50
10"	250	406,4	361,9	25,4	30,2	12	250	300	19	50	50
12"	300	482,6	431,8	25,4	31,8	12	300	355	19	50	50
14"	350	533,4	476,2	28,6	34,9	12	330	388	19	50	50
16"	400	596,9	539,7	28,6	36,5	16	382	443	19	50	50
18"	450	635,0	577,8	31,7	39,7	16	433	502	19	50	50
20"	500	698,5	635,0	31,7	42,9	20	483	552	19	50	50
24"	600	812,2	749,3	34,9	47,6	20	585	657	19	50	50

FLANGE ASME B 16.5 ASTM A 105 N - LIFTING RING ASTM A 285 C - FINAL COATING WITH ANTICORROSION FINISH



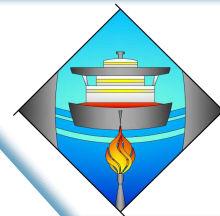

Towing Lifting Blind Flanges

Flange ASME B 16.5 Class 150lb & 300lb

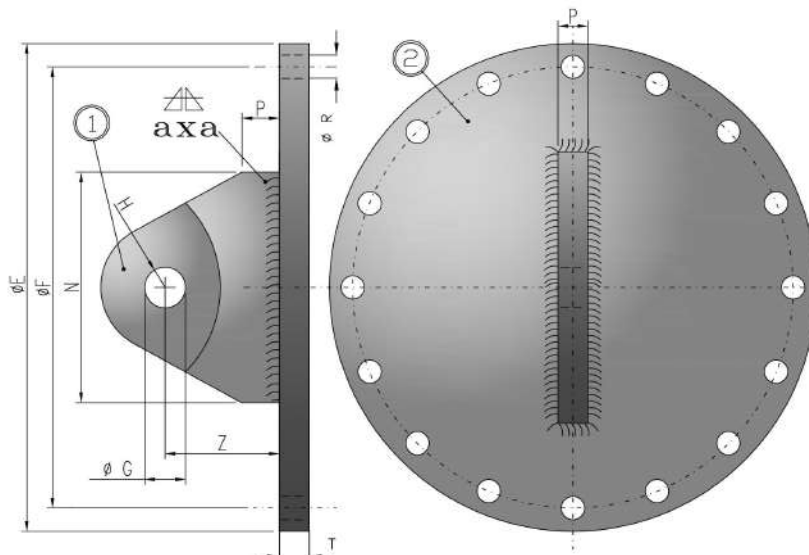

COATING:

- Galvanized Flanges according to BS 729, par. 1, (600g/mq), BS EN ISO 1461.
- Or Hot-Zinc-Sprayed Flanges according to BS 2569 par. 1, (100 micron).

FLANGE FACE:

- Sarrated Finish according to BS 1560 sez. 3 par. 3,3,1 over its complete area after welding.

ITEM - MATERIAL:

- Lifting Lug - ASTM A 516 GR 70 or equivalent.
- Lifting Blind Flange - ASTM A 105 N.

DIMENSIONS AND TOLERANCES ACCORDING TO ASME B 16.5 CLASS 150lb														LOADS			
N.D.	N.D.	Ø E	Ø F	Ø R	T	HOLES	N	α	P	axa	Ø G	H	Z	WEIGHT	SWL	PROOF	BREAKING
(Inch)	(mm)	(mm)	(mm)	(mm)	(mm)	(N°)	± 2 (mm)	(mm)	± 1 (mm)	(mm)	± 1 (mm)	± 1 (mm)	± 1 (mm)	(Kg)	(kN)	(kN)	(kN)
8"	200	342,9	298,4	22,2	28,6	8	150	60	33	15	28	45	80	46	50	125	250
10"	250	406,4	361,9	25,4	30,2	12	180	60	33	15	28	45	80	54	70	175	350
12"	300	482,6	431,8	25,4	31,8	12	190	60	33	15	28	45	80	75	100	250	500
16"	400	596,9	539,7	28,6	36,5	16	240	60	33	15	28	45	80	86	150	375	750
DIMENSIONS AND TOLERANCES ACCORDING TO ASME B 16.5 CLASS 300lb														LOADS			
8"	200	381,0	330,2	25,4	41,3	12	150	60	33	15	28	45	80	N.A.	50	125	250
10"	250	444,5	387,3	28,6	47,6	16	180	60	33	15	28	45	80	N.A.	70	175	350
12"	300	520,5	450,8	32,0	50,8	16	190	60	33	15	28	45	80	N.A.	100	250	500
16"	400	647,5	571,5	35,0	57,2	20	240	60	33	15	28	45	80	N.A.	150	375	750



Welding Neck and Blind Flanges

Flange ASME B 16.5 Class 150lb

Prod. Code: 050

FLANGES ASA: S.O., W.N., S.W., Blind, Lap Joint, Threaded

FLANGES UNI: Flat, Welding neck, Blind, Lap Joint, Threaded

FITTINGS TEE equal and reducer, Plates, Crosses stomer, Concentric and Eccentric Curves

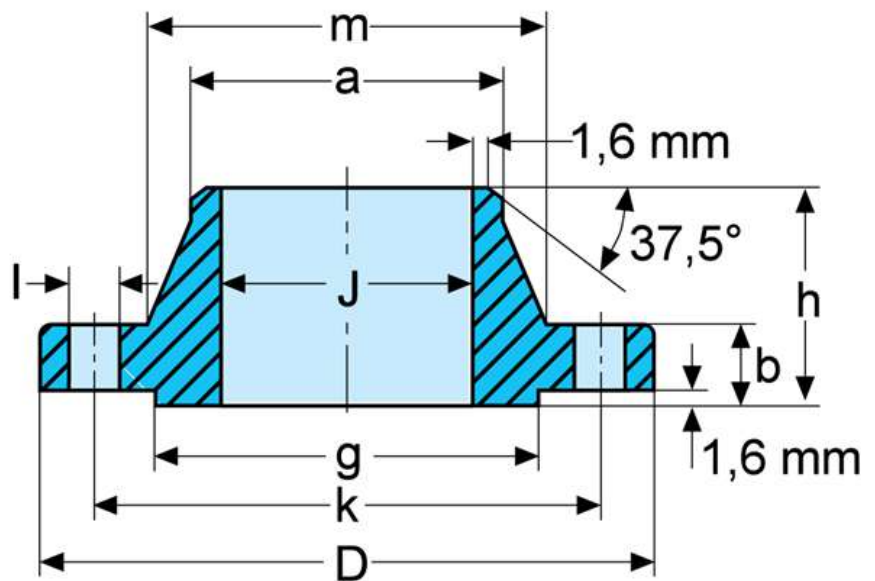

FLANGE ACCORDING TO ASME B 16.5 - CLASS 150lb (PN20) RAISED FACE													WELDING NECK	BLIND
N.D. (inch)	D.N. (mm)	D (mm)	b (mm)	a (mm)	J (mm)	m (mm)	g (mm)	h (mm)	K (mm)	No. Holes	l (mm)	Bolts Inch x mm	Weight (Kg)	Weight (Kg)
4"	100	229	23,8	114,3	102,4	135	157,2	76,2	190,5	8	19	5/8"x95	6,8	7,7
5"	125	254	23,8	141,3	128,3	164	185,7	88,9	215,9	8	22	3/4"x100	8,6	9,1
6"	150	279	25,4	168,3	154,2	192	215,9	88,9	241,3	8	22	3/4"x110	10,9	11,8
8"	200	343	28,6	219,1	202,7	246	269,9	101,6	298,4	8	22	3/4"x115	17,7	20,4
10"	250	406	30,2	273	254,5	305	323,8	101,6	361,9	12	25	7/8"x125	23,6	31,8
12"	300	483	31,7	323,8	304,8	365	381	114,3	431,8	12	25	7/8"x125	36,3	50
14"	350	533	34,9	355,6	336,5	400	412,7	127	476,2	12	29	1"x145	46,3	60
16"	400	597	36,5	406,4	387,3	457	469,9	127	539,7	16	29	1"x145	57,7	77
18"	450	635	39,7	457,2	438,1	505	533,4	139,7	577,8	16	32	1,1/8"x160	63,6	95
20"	500	699	42,9	508	488,9	559	584,2	144,5	635	20	32	1,1/8"x170	77,2	123
24"	600	813	47,6	609,6	590,5	664	692,1	152,4	749,3	20	35	1,1/4"x190	118	187

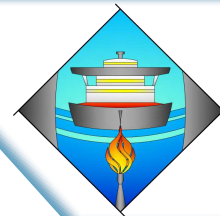

Welding Neck and Blind Flanges

Flange ASME B 16.5 Class 300lb

FLANGES ASA: S.O., W.N., S.W., Blind, Lap Joint, Threaded

FLANGES UNI: Flat, Welding neck, Blind, Lap Joint, Threaded

FITTINGS TEE equal and reducer, Plates, Crosses stomer, Concentric and Eccentric Curves

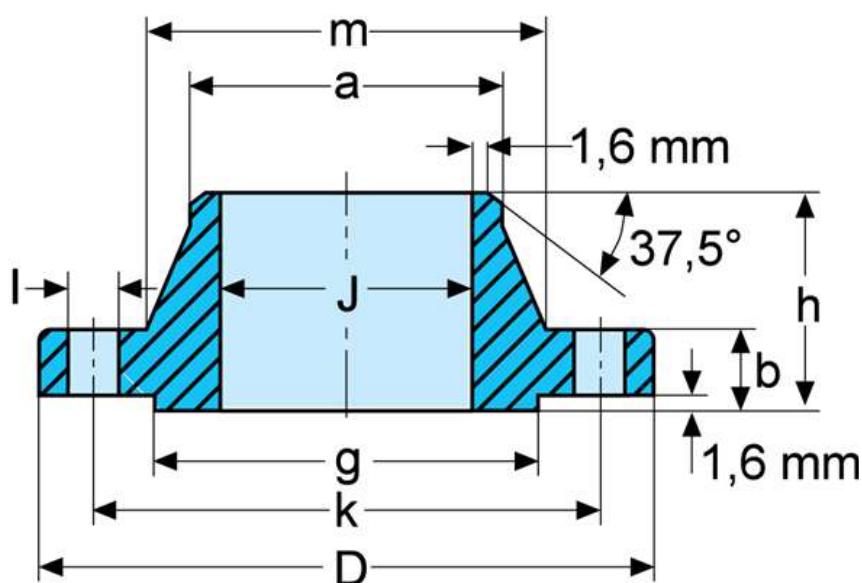

FLANGE ACCORDING TO ASME B 16.5 - CLASS 300lb (PN50) RAISED FACE													WELDING NECK	BLIND
N.D. (inch)	D.N. (mm)	D (mm)	b (mm)	a (mm)	J (mm)	m (mm)	g (mm)	h (mm)	K (mm)	No. Holes	l (mm)	Bolts Inch x mm	Weight (Kg)	Weight (Kg)
4"	100	254	32	114,3	102,4	146	157,2	86	200	8	22	3/4"x120	11,3	12,2
5"	125	279	35	141,3	128,3	178	185,7	98	235	8	22	3/4"x125	14,5	15,9
6"	150	318	37	168,3	154,2	206	215,9	98	270	12	22	3/4"x125	19	22,7
8"	200	381	41	219,1	202,7	260	269,9	111	330	12	25	7/8"x145	30,5	37
10"	250	445	48	273	254,5	321	323,8	118	387	16	29	1"x170	41,5	58
12"	300	521	51	323,8	304,8	375	381	130	451	16	32	1,1/8"x185	62,5	84
14"	350	584	54	355,6	336,5	425	412,7	143	514	20	32	1,1/8"x190	84,5	107
16"	400	648	57	406,4	387,3	483	469,9	146	572	20	35	1,1/4"x205	111,5	139
18"	450	711	60	457,2	438,1	533	533,4	159	629	24	35	1,1/4"x210	138	177
20"	500	775	64	508	488,9	587	584,2	162	686	24	35	1,1/4"x225	172	223
24"	600	914	70	609,6	590,5	702	692,1	168	813	24	41	1,1/2"x250	247	342



Welding Neck and Blind Flanges

Flange ASME B 16.5 Class 600lb

Prod. Code: 052

FLANGES ASA: S.O., W.N., S.W., Blind, Lap Joint, Threaded

FLANGES UNI: Flat, Welding neck, Blind, Lap Joint, Threaded

FITTINGS TEE equal and reducer, Plates, Crosses stomer, Concentric and Eccentric Curves

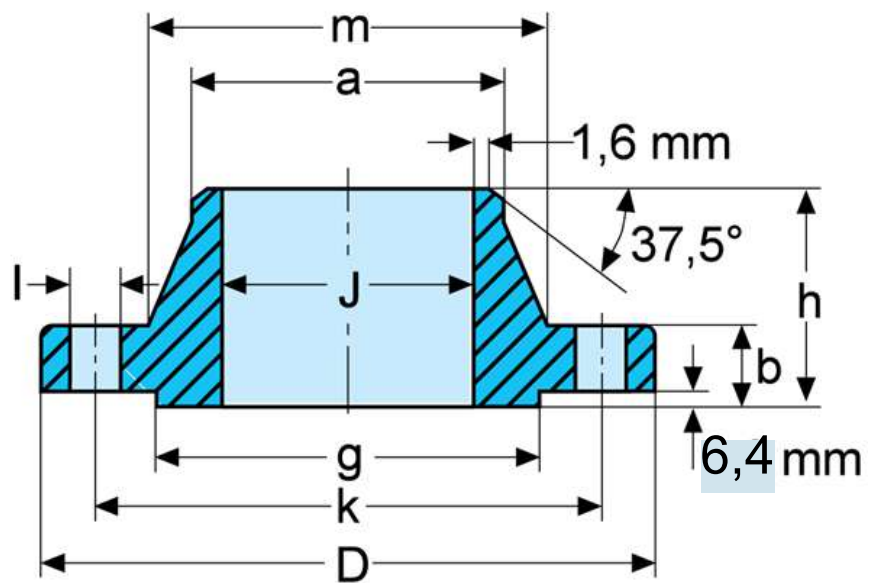

FLANGE ACCORDING TO ASME B 16.5 - CLASS 600lb (PN100) RAISED FACE													WELDING NECK	BLIND
N.D. (inch)	D.N. (mm)	D (mm)	b (mm)	a (mm)	J (mm)	m (mm)	g (mm)	h (mm)	K (mm)	No. Holes	l (mm)	Bolts Inch x mm	Weight (Kg)	Weight (Kg)
4"	100	273	38	114,3	**	152	157,2	102	216	8	25	7/8"x150	19	18,5
5"	125	330	44	141,3	**	189	185,7	114	267	8	29	1"x175	31	30,5
6"	150	356	48	168,3	**	223	215,9	117	292	12	29	1"x185	37	38,5
8"	200	419	56	219,1	**	273	269,9	133	349	12	32	1,1/8"x205	53	62,5
10"	250	508	63,5	273	**	343	323,8	152	432	16	35	1,1/4"x230	86	104
12"	300	559	67	323,8	**	400	381	156	489	20	35	1,1/4"x235	103	133
14"	350	603	70	355,6	**	432	412,7	165	527	20	38	1,3/8"x250	157	170
16"	400	686	76	406,4	**	495	469,9	178	603	20	41	1,1/2"x265	218	237
18"	450	743	83	457,2	**	546	533,4	184	654	20	44	1,5/8"x285	252	300
20"	500	813	89	508	**	610	584,2	190	724	24	44	1,5/8"x305	313	385
24"	600	940	102	609,6	**	718	692,1	203	838	24	51	1,7/8"x340	443	530

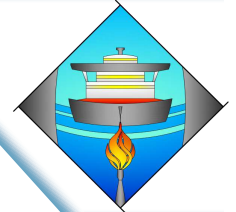

Vacuum Plexiglass Flanges

Transparent Flange for Vacuum Test

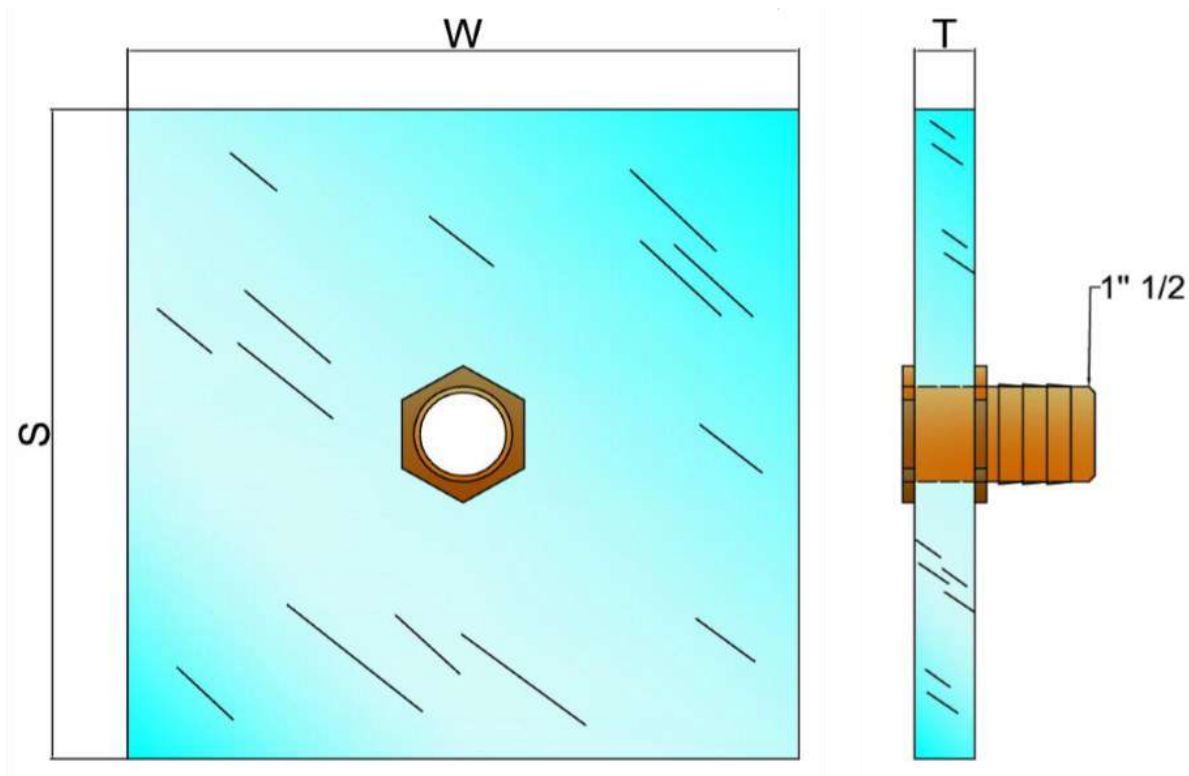

VACUUM FLANGE DIMENSIONS					
N.D. HOSE (Inch)	N.D. HOSE (mm)	W (mm)	S (mm)	T (mm)	WEIGHT (Kg)
6"	150	318	318	50	N.A.
8" - 10"	200 - 250	445	445	50	N.A.
12"	300	521	521	50	N.A.
16" - 20"	400 - 500	775	755	50	N.A.
24"	600	915	915	50	N.A.

FLANGE MATERIAL - PLEXIGLASS



Stud Bolts c/w Nuts

For Flange ASME B 16.5 Class 150lb & 300lb

Prod. Code: 350

Prod. Code: 351

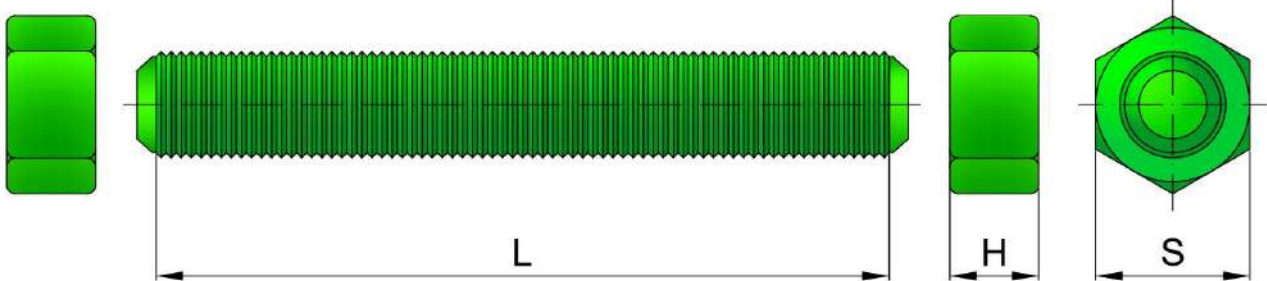

STUD BOLTS and NUTS for FLANGE ASME B 16.5 CLASS 150lb

FLANGE SIZE (Inch / mm)	HOLES (N°)	BOLTS				NUTS			TIGHTENING TORQUE (Nm)	WEIGHT APPROX. (Kg)
		N.D. THREAD	THREAD UNC	L (mm)	L (inch)	H (mm)	H (Inch)	S (Inch)		
4" / 100	8	5/8"	11	95	3.3/4"	15,47	39/64"	1.1/16"	231	0,210
5" / 125	8	3/4"	10	100	3.30/32"	18,65	47/64"	1.1/4"	406	0,346
6" / 150	8	3/4"	10	110	4.5/16"	18,65	47/64"	1.1/4"	406	0,382
8" / 200	8	3/4"	10	115	4.1/2"	18,65	47/64"	1.1/4"	406	0,395
10" / 250	12	7/8"	9	125	4.15/16"	21,82	55/64"	1.7/16"	651	0,604
12" / 300	12	7/8"	9	125	4.15/16"	21,82	55/64"	1.7/16"	651	0,604
14" / 350	12	1"	8	145	5.3/4"	25	63/64"	1.5/8"	970	0,879
16" / 400	16	1"	8	145	5.3/4"	25	63/64"	1.5/8"	970	0,879
18" / 450	16	1.1/8"	8	160	6.5/16"	32,14	1.17/64"	1.13/16"	1421	1,160
20" / 500	20	1.1/8"	8	170	6.11/16"	32,14	1.17/64"	1.13/16"	1421	1,250
24" / 600	20	1.1/4"	8	190	7.1/2"	30,95	1.7/32"	2"	1994	1,698

STUD BOLTS and NUTS for FLANGE ASME B 16.5 CLASS 300lb

4" / 100	8	3/4"	10	120	4.6/8"	18,65	47/64"	1.1/4"	406	0,398
5" / 125	8	3/4"	10	125	4.15/16"	18,65	47/64"	1.1/4"	406	0,406
6" / 150	12	3/4"	10	125	4.15/16"	18,65	47/64"	1.1/4"	406	0,406
8" / 200	12	7/8"	9	145	5.3/4"	21,82	55/64"	1.7/16"	651	0,620
10" / 250	16	1"	8	170	6.11/16"	25	63/64"	1.5/8"	970	0,950
12" / 300	16	1.1/8"	8	185	7.5/16"	28,17	1.7/64"	1.13/16"	1421	1,670
14" / 350	20	1.1/8"	8	190	7.1/2"	28,17	1.7/64"	1.13/16"	1421	1,680
16" / 400	20	1.1/4"	8	205	8.1/16"	30,95	1.7/32"	2"	1994	1,755
18" / 450	24	1.1/4"	8	210	8.1/4"	30,95	1.7/32"	2"	1994	1,767
20" / 500	24	1.1/4"	8	225	8.55/64"	30,95	1.7/32"	2"	1994	1,894
24" / 600	24	1.1/2"	8	247	9.23/32"	37,30	1.15/32"	2.2/3"	3556	2,937

MATERIAL	BOLT	NUTS	COATING
ALLOY STEEL	ASTM A 193 Gr. B7	ASTM A 194 Gr. 2H	PTFE
STAINLESS STEEL	316 SS	316 SS	—
MONEL 400	MONEL 400	MONEL 400	—
MONEL K500	MONEL K500	MONEL K500	—

NOTES

1. Thread spec. ASME B 1.1
2. All Items are provided with: materials certificate and dimensional report random of 10%.
3. Other lengths of Bolts on request.



Exagonal Head Bolts c/w Nut

For Flange UNI EN 1092-1 (Ex UNI 2278-67) PN16

Prod. Code: 352

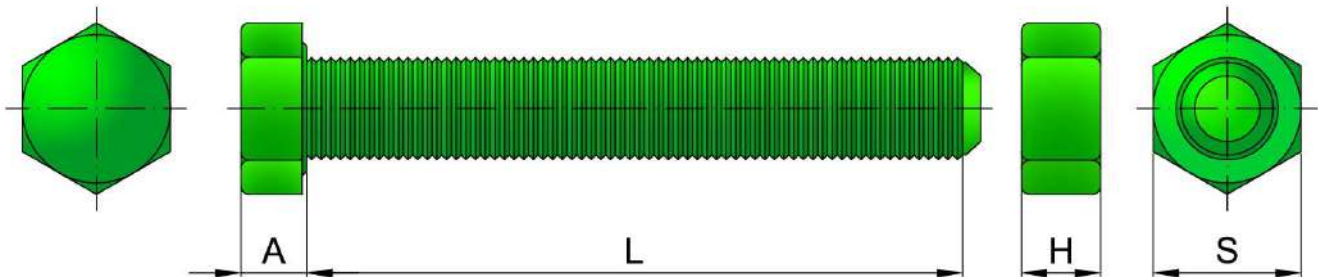

EXAGONAL HEAD BOLTS and NUT for FLANGE UNI EN 1092-1 (Ex UNI 2278-67) PN16

FLANGE SIZE (Inch / mm)	HOLES (N°)	BOLTS					NUTS			TIGHTENING TORQUE (Nm)	WEIGHT APPROX. (Kg)
		N.D. THREAD	THREAD PITCH	L (mm)	L (inch)	A (mm)	H (mm)	H (Inch)	S (mm)		
4" / 100	8	M16	2 mm	60	2.23/64"	10	13	33/64"	24	231	0,155
5" / 125	8	M16	2 mm	65	2.9/16"	10	13	33/64"	24	406	0,163
6" / 150	8	M20	2,5 mm	70	2.3/4"	13	16	5/8"	30	406	0,295
8" / 200	12	M20	2,5 mm	75	2.61/64"	13	16	5/8"	30	406	0,307
10" / 250	12	M22	2,5 mm	90	3.35/64"	14	18	45/64"	32	651	0,321
12" / 300	12	M22	2,5 mm	90	3.35/64"	14	18	45/64"	32	651	0,321
14" / 350	16	M22	2,5 mm	100	3.15/16"	14	18	45/64"	32	970	0,382
16" / 400	16	M27	3 mm	100	3.15/16"	17	22	55/64"	41	970	0,766
18" / 450	20	M27	3 mm	110	4.21/64"	17	22	55/64"	41	1421	0,810
20" / 500	20	M30	3,5 mm	110	4.21/64"	19	24	15/16"	46	1421	1,052
24" / 600	20	M33	3,5 mm	120	4.23/32"	21	26	1.1/32"	50	1994	1,378

MATERIAL	BOLT	NUTS	COATING
ALLOY STEEL	ASTM A 193 Gr. B7	ASTM A 194 Gr. 2H	PTFE
STAINLESS STEEL	316 SS	316 SS	—
MONEL 400	MONEL 400	MONEL 400	—
MONEL K500	MONEL K500	MONEL K500	—

NOTES

1. Thread spec. UNI 5739
2. All Items are provided with: materials certificate and dimensional report random of 10%.
3. Other lengths of Bolts on request.