

**GASKETS & ELECTRICALLY
INSULATION KITS**

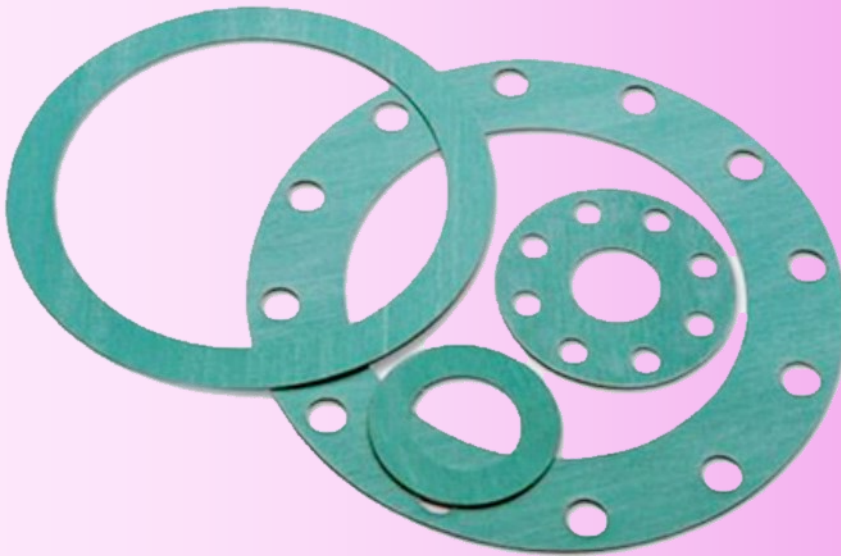

- **Aramid Fiber Gaskets**
- **Spiral-Wounds Gaskets**
- **Electrically Insulation Kits**

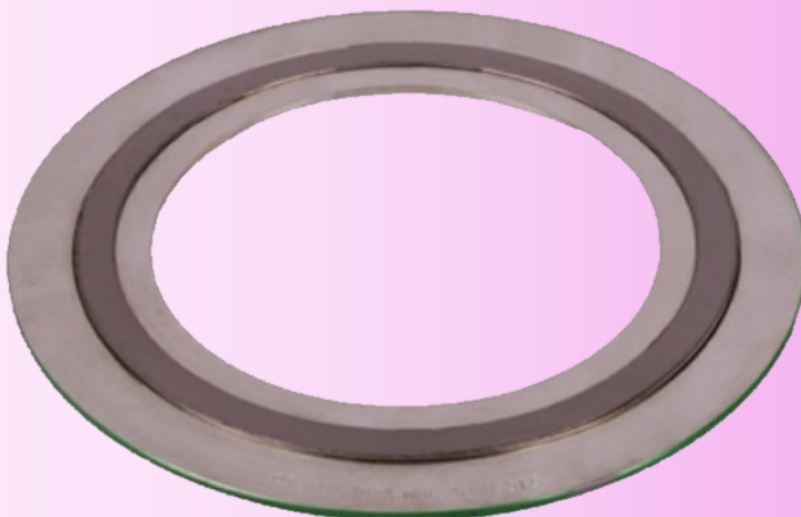

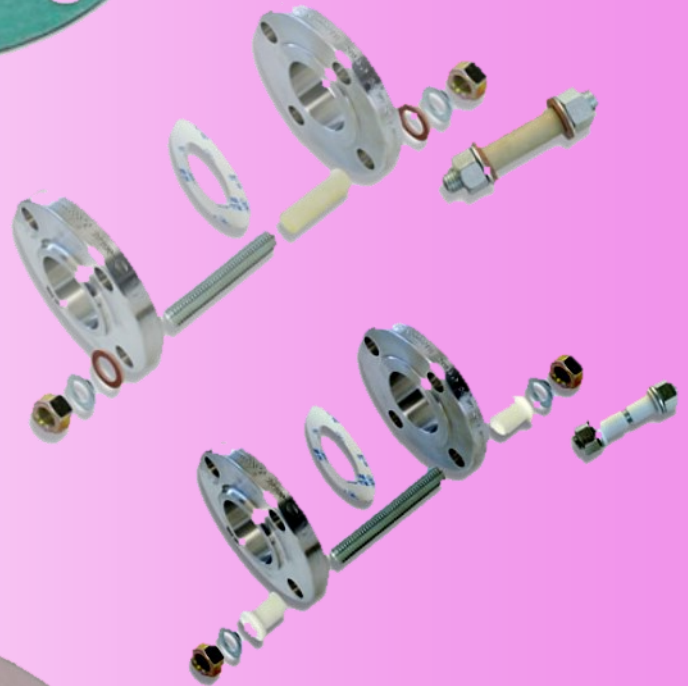

Aramid Fiber Gasket Technical Data

Universal Gasket Material for every equipment and Service

High quality compressed synthetic fibre jointing sheets based on aramide and special mineral fibers mixed in a rubber NBR matrix. This material has got high compressibility and low gas permeability, excellent characteristics for many industrial services. Material suitable for use with air, water, oils, hydrocarbons and gases. Particularly suitable for use in compressors, and in shipbuilding and hydraulic systems

Homologated by:

DVGW (DIN 3535-6)
 DVGW (VP401)
 WRAS (BS 6920)
 AGA (AG 208)

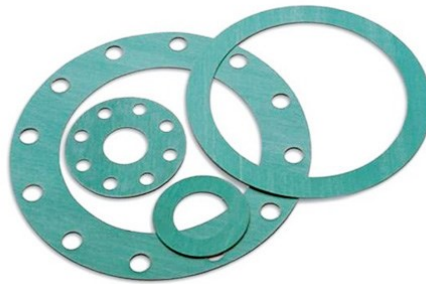

Working conditions:

Max pressure: 100 bar
 Temperature: -20 / 400 °C

Is not advised the use in the maximum temperature and at the same time with the maximum pressure.

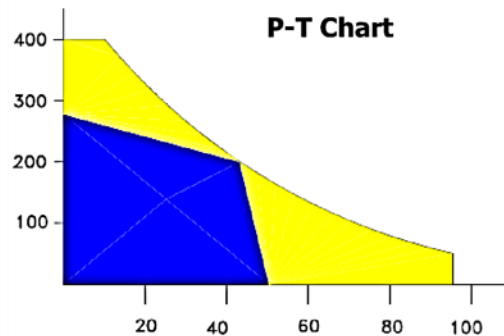

Technical data (*)

Properties	Referring to	Value	UM
Density		1,65 ±10%	g/cm ³
Compressibility	ASTM F36	7 - 15	%
Recovery		> 50	%
Transverse tensile strength	ASTM F152	10	MPa
Gas permeability	DIN3535/6	1	cm ³ /min
Thickness increase ASTM F-146 after:	ASTM F146		
Immersion in ASTM oil N°1 5h 150°C		< 1	%
Immersion in ASTM oil N°3 5h 150°C		< 4	%
Immersion in ASTM fuel B 5h RT		< 5	%

σ_{vu} (MPa)	σ_{vo} (MPa)	σ_{Bo} (MPa)			Y (MPa)	m	R _z (μ m)
		150°C	200°C	300°C			
30	200	100	-	-	30	2.0	160

(*) the maximum exercise's condition depend on many factor as the gasket' s dimension, the clamping value between the flanges, etc

Material description

Colour: Blu
 Standard thk.: 0.5; 0.8; 1.0; 1.5; 2.0; 3.0 (other on request)



FF Aramidic Fiber Gaskets

For Flange ASME B 16.5 Class 150lb & 300lb

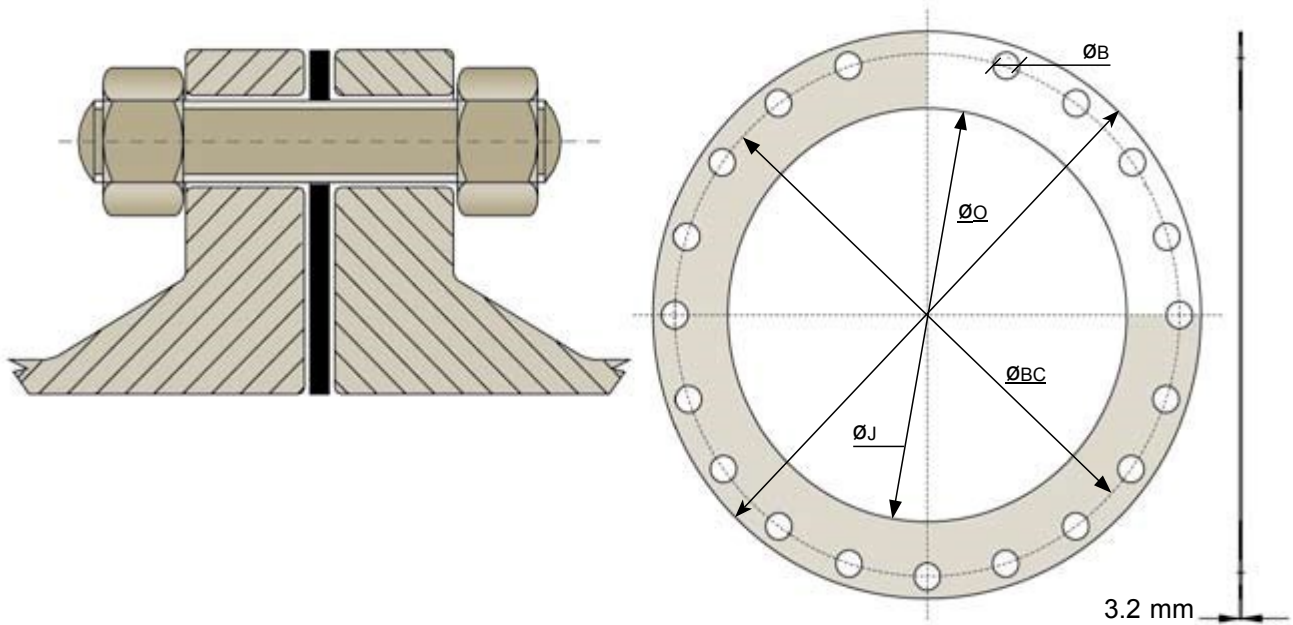

CLASS 150lb						
FLANGE SIZE (Inch)	FLANGE SIZE (mm)	Ø J (mm)	Ø O (mm)	Ø BC (mm)	HOLES (N°)	WEIGHT (Kg)
6"	150	154,2	279,5	241,3	8	0,21
8"	200	202,7	343,0	298,4	8	0,29
10"	250	254,5	406,5	361,9	12	0,37
12"	300	304,8	482,5	431,8	12	0,54
16"	400	387,3	597,0	539,7	16	0,80
20"	500	488,9	698,5	635,0	20	0,93
24"	600	590,5	813,0	749,3	20	1,18
CLASS 300lb						
6"	150	154,2	317,5	269,9	12	0,31
8"	200	202,7	381,0	330,2	12	0,40
10"	250	254,5	444,5	387,3	16	0,49
12"	300	304,8	520,5	450,8	16	0,67
16"	400	387,3	647,5	571,5	20	1,03
20"	500	488,9	774,5	685,8	24	1,40
24"	600	590,5	914,5	812,8	24	1,89



RF Aramidic Fiber Gaskets

For Flange ASME B 16.5 Class 150lb & 300lb

Prod. Code: 310

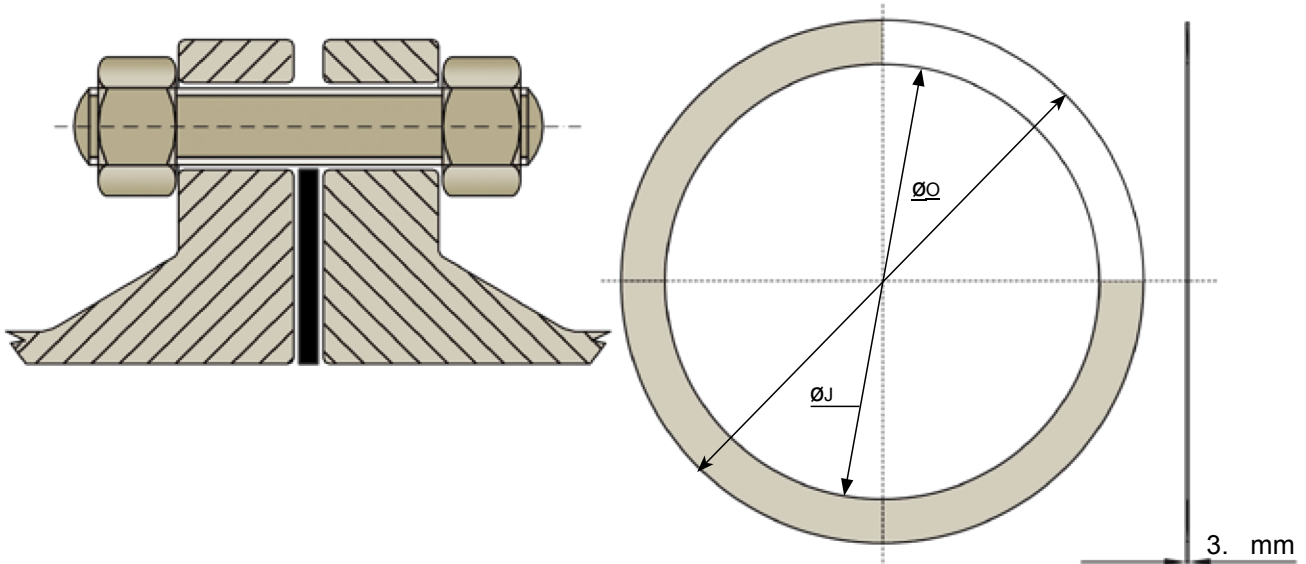

CLASS 150lb				
FLANGE SIZE (Inch)	FLANGE SIZE (mm)	$\varnothing J$ (mm)	$\varnothing O$ (mm)	WEIGHT (Kg)
6"	150	154,2	216	0,10
8"	200	202,7	270	0,14
10"	250	254,5	324	0,19
12"	300	304,8	381	0,30
16"	400	387,3	470	0,47
20"	500	488,9	584	0,52
24"	600	590,5	692	0,68
CLASS 300lb				
6"	150	154,2	216	0,16
8"	200	202,7	270	0,22
10"	250	254,5	324	0,27
12"	300	304,8	381	0,35
16"	400	387,3	470	0,60
20"	500	488,9	584	0,85
24"	600	590,5	692	1,09



Spiral-Wounds Gaskets

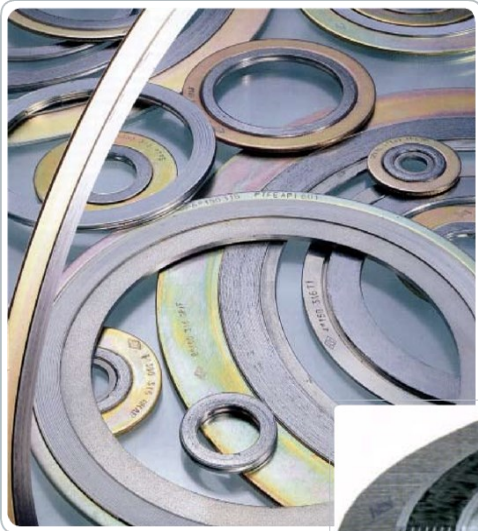

The spiral wound gaskets are composed of a metallic continuous strip with a special shaped profile, coupled with a continuous filling strip evenly wound in concentric spirals under constant stress.

The spiral wound gaskets are reinforced on the inner and outer diameters by winding of several electrically welded spirals of metal only.

The main property of the spiral wound gaskets, owing to the elastic action of the special metallic strip profile, is that offers a perfect sealing under all fluctuating pressure and temperature conditions, also where the temperature excursion has considerable values, maintaining tightening by elastic recovering.

The spiral gaskets can be employed on refining plants, chemical or petrochemical plants, nuclear plants, compressors pipings, cylinder heads, heat exchangers.

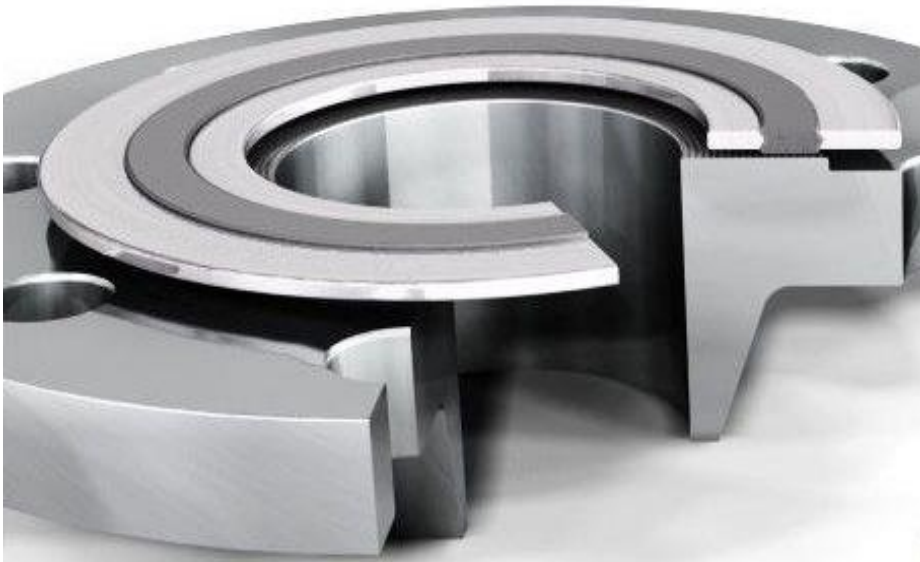



S13 Spiral-Wounds Gaskets

For Flange ASME B 16.5 Class 150lb & 300lb

Prod. Code: 320

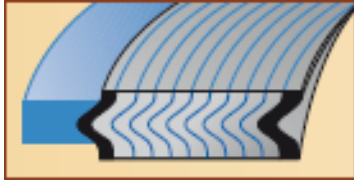

In this case the gasket is provided with the outer ring. Even in this case the ring has different functions but mainly that of acting as a centering ring on the flange, thus facilitating its assembly and preventing the lateral expansion of the seal (blow out). General application for flanges on a smooth surface.

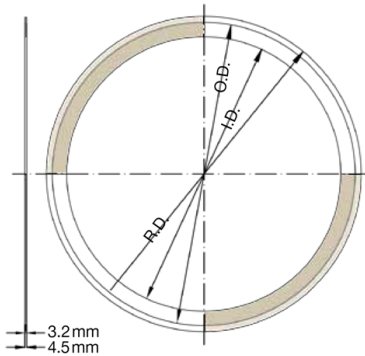

For optimum sealing performance spiral wound gaskets should be compressed to the following thicknesses.

INITIAL GASKET THICKNES Inch	RECOMMENDED COMPRESSED THICKNESS Inch
0,175	0,125+0,135

Spiral wound gaskets with internal or external guide rings should be fully compressed to the guide ring. This will not damage the gasket or affect the sealing performance.

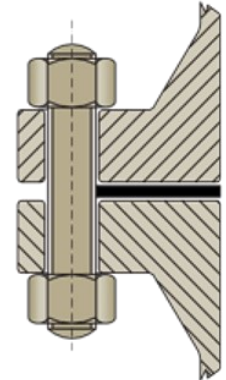

**DIMENSION ACCORDING TO ASME B 16.20
FOR FLANGE ASME B 16.5 CLASS 150lb**

FLANGE SIZE (Inch)	FLANGE SIZE (mm)	I.D. (mm)	O.D. (mm)	R.D. (mm)	WEIGHT (Kg)
6"	150	182,6	209,6	222,3	0,27
8"	200	233,4	263,7	279,4	0,39
10"	250	287,3	317,5	339,9	0,56
12"	300	339,9	374,7	409,7	0,90
16"	400	422,4	463,6	514,4	1,39
20"	500	525,5	577,9	606,6	1,49
24"	600	628,7	685,8	717,6	1,77

**DIMENSION ACCORDING TO ASME B 16.20
FOR FLANGE ASME B 16.5 CLASS 300lb**

6"	150	182,6	209,6	251,0	0,53
8"	200	233,4	263,7	308,1	0,71
10"	250	287,3	317,5	362,0	0,87
12"	300	339,9	374,7	422,4	1,12
16"	400	422,4	463,6	539,8	2,01
20"	500	525,5	577,9	654,1	2,59
24"	600	628,7	685,8	774,7	3,45

NOTES:

- Strip material: AISI 316
- Filler material: PTFE or Graphite
- Thickness: 4,45 mm
- Centering thickness: $2,97 \div 3,33$

MATERIAL LIST		
ITEM	PART DESCRIPTION	MATERIAL DESCRIPTION
1	OUTSIDE HOOP	STAINLESS STEEL AISI 316
2	CENTRAL RING	ROLLED CARBON STEEL



S15 Spiral-Wounds Gaskets

For Flange ASME B 16.5 Class 150lb & 300lb

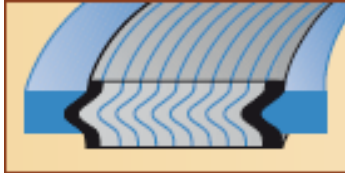

The gasket is provided with both rings. The internal ring is used in cases of high pressure and operating temperature or where corrosive or toxic fluids are present, in all of the applications with PTFE filters. It is advised with graphite fillers for dimensions 24" and larger for the 900 class, 12" for the 1500 class and 4" for the 2500 class.

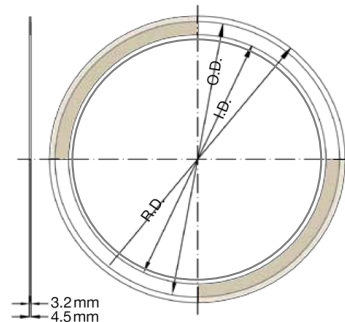

For optimum sealing performance spiral wound gaskets should be compressed to the following thicknesses.

INITIAL GASKET THICKNES Inch	RECOMMENDED COMPRESSED THICKNESS Inch
0,175	0,125+0,135

Spiral wound gaskets with internal or external guide rings should be fully compressed to the guide ring. This will not damage the gasket or affect the sealing performance.

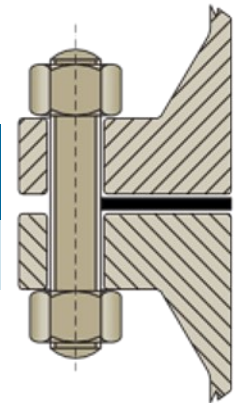

DIMENSION ACCORDING TO ASME B 16.20 FOR FLANGE ASME B 16.5 CLASS 150lb					
FLANGE SIZE (Inch)	FLANGE SIZE (mm)	I.D. (mm)	O.D. (mm)	R.D. (mm)	WEIGHT (Kg)
6"	150	157,23	209,6	222,3	0,27
8"	200	215,90	263,7	279,4	0,39
10"	250	268,22	317,5	339,9	0,56
12"	300	317,50	374,7	409,7	0,90
16"	400	400,05	463,6	514,4	1,39
20"	500	500,13	577,9	606,6	1,49
24"	600	603,25	685,8	717,6	1,77
DIMENSION ACCORDING TO ASME B 16.20 FOR FLANGE ASME B 16.5 CLASS 300lb					
6"	150	157,23	209,6	222,3	0,53
8"	200	215,90	263,7	279,4	0,71
10"	250	268,22	317,5	339,9	0,87
12"	300	317,50	374,7	409,7	1,12
16"	400	400,05	463,6	514,4	2,01
20"	500	500,13	577,9	606,6	2,59
24"	600	603,25	685,8	717,6	3,45

NOTES:

- Strip material: AISI 316
- Filler material: PTFE or Graphite
- Thickness: 4,45 mm
- Centering thickness: $2,97 \div 3,33$

MATERIAL LIST		
ITEM	PART DESCRIPTION	MATERIAL DESCRIPTION
1	INNER HOOP	STAINLESS STEEL AISI 316
2	OUTSIDE HOOP	STAINLESS STEEL AISI 316
3	CENTRAL RING	ROLLED CARBON STEEL



Spiral-Wounds Assembly Techniques

Flanges

Check that the flange faces are clean, in good condition and with a turned surface finish within the following range : 3.2 to 6.3 micro meters (125 to 250 micro inches).

Bolting

Ensure that the correct bolting material is utilized to suit the operating conditions, taking into account the limitation of low yield strength bolts. Ensure that the use of bolt lubrication is employed. For torque type tightening methods we recommend the use of molybdenum disulphide bolt lubrication or similar nickel compound.

Torque required to produce bolt stress

The torque or turning effort required to produce a certain stress in bolting is dependent upon a number of conditions, some of which are: diameter of bolt, type and number of threads on bolt, material of bolt, condition of nut surfaces, lubrication of bolt threads and nut bearing surfaces. The tables below reflect the results of many tests to determinate the relation between torque and bolt stress. Value are based on steel bolting well lubricated with heavy graphite and oil mixture. It was found that a non- lubricated bolt has an efficiency of about 50 per cent of a well lubricated bolt and also that different lubricants produce results varying between the limits of 50 and 100 per cent of the tabulated stress figures.

WHERE

- dD = Average diameter of gasket in mm
- bD = Effective width of gasket in mm
- P = Fluid pressure in N/mm^2
- Ct = Coefficient of tightening uncertainty

TIPYCAL Ct VALUE

- 1,15 Bolt tensioner
- 1,25 Torque wrench with automatic in-out
- 1,65 Motor-operated impulse wrench
- 1,40 Motor-operated rotative wrench, with torque indication
- 2,00 Impact wrench

TIGHTENING PROCEDURE

- 50% of required torque
- 80% of required torque
- 100% of required torque

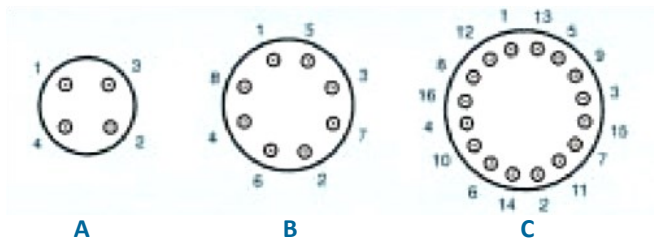

STUD BOLTS TYPE	STUD BOLTS MATERIAL	TORQUE VALUE (NM)	STUD BOLTS MATERIAL	TORQUE VALUE (NM)
M.10	ASTM A 193 B7/B7M/L7/L7M	65	ASTM A 193 B8/B8M	30
M.12		90		57
M.14		120		90
M.16		200		140
M.18		290		180
M.20		410		260
M.22		550		330
M.24		700		440
M.27		1050		650
M.30		1400		780
M.33		1800		890
M.36		2100		1050
M.42		3300		1620
M.48		5050		2450



Electrically Insulation kits

For Flange ASME B 16.5 Class 150lb & 300lb

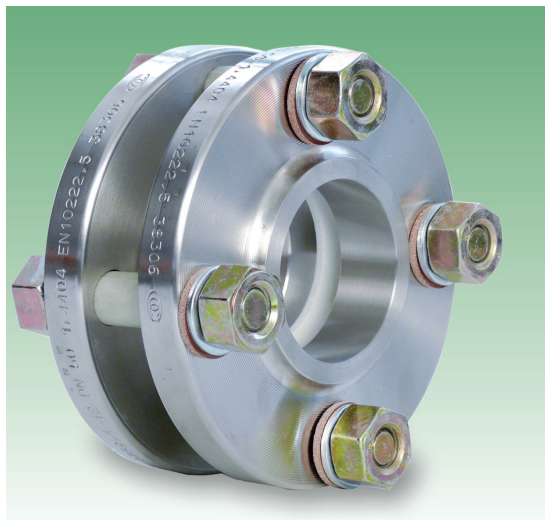

Galvanic or electrochemical corrosion is a wet process that takes place when two metals of different electric potential, (or two elements of the same metal with different electrical potential), are in direct contact (**galvanic coupling**), and are immersed in a third element (electrolyte).

A short-circuit cell is formed (**galvanic cell**) in which the electrodes are constituted by the two coupled materials. A flow of electrons is generated from the oxidizing lower potential metal (Anode or negative pole) towards the reducing metal with higher potential (Cathode or positive pole).

There occurs a direct current circulation from the cathode to the anode area, whose effect is the corrosion of materials. Electrical conductivity of an aggressive environment is a key factor that directly influences the process of corrosion by contact.

In high conductivity means the attack is intense and spreads its effect over large distances, whilst in environments with high oxidization resistance, corrosion effect is limited to the anode area near the junction with the cathode. For such reasons this type of corrosion is particularly severe in sea water, but not so strong in fresh waters which show lower conductivity of at least two orders of magnitude.

Prevents the process of galvanic corrosion by ensuring the interruption of electrical continuity between adjacent flanges and isolating each component **without interfering with the proper tightening**.

L-SERIES

Our kit is composed of a gasket manufactured with an insulating material suitable for the specific use, one insulation sleeve for each bolt, a couple of insulating and metallic washers for each nut.

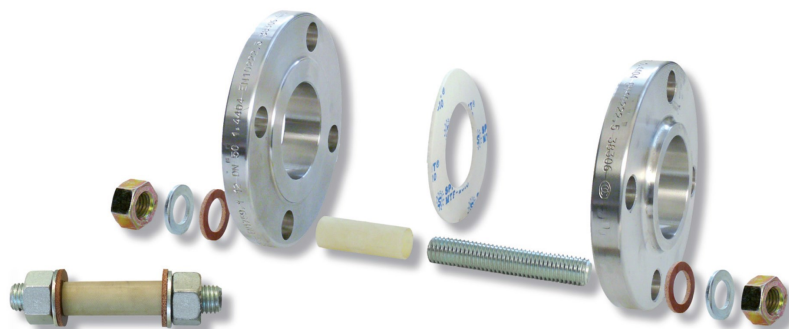

T-SERIES

Our kit is composed of a gasket manufactured with an insulating material suitable for the specific use, a couple of sleeves with washers for each bolt. Inserting sleeves into the flange holes between bolt, nuts and metallic washers the electrical insulation is guaranteed.

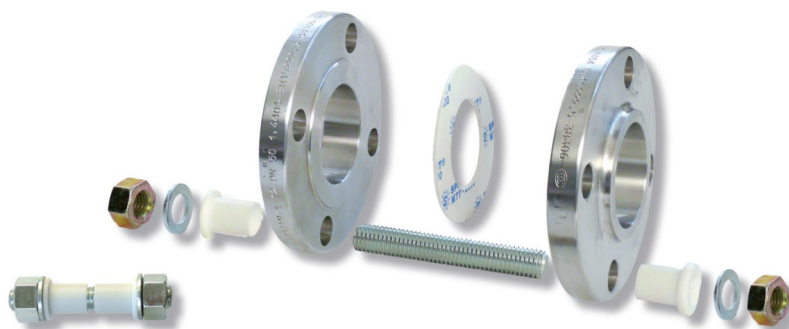



Electrically Insulation kits

For Flange ASME B 16.5 Class 150lb & 300lb

Prod. Code: 340

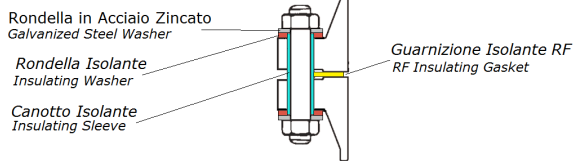
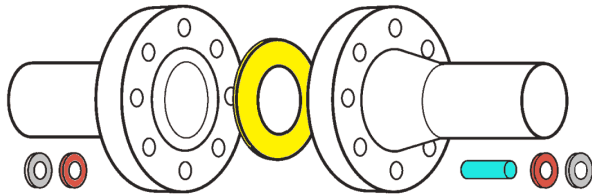

F TYPE - RAISED FACE GASKET (RF)

Kit composed by an insulating gasket type RF (made in G11/NEOPRENE, G11/EPDM, G11/NBR, G11/FKM, G11/PTFE, Virgin or modified PTFE).

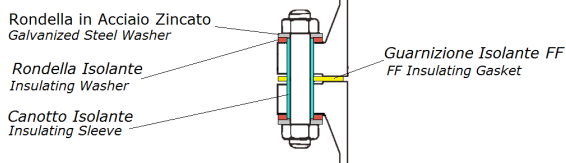
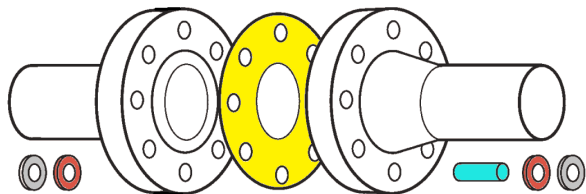

E TYPE - FULL FACE GASKET (FF)

The gasket put between the flanges doesn't allow any electrical conductive parts to get into the assembling. Thanks to this gasket we reduce at minimum the risk of an electrical arc between the flanges. Gasket will be manufactured in insulating material(i.e. G11/NEOPRENE, G11/EPDM, G11/NBR, G11/FKM, G11/PTFE, VIRGIN OR MODIFIED PTFE).

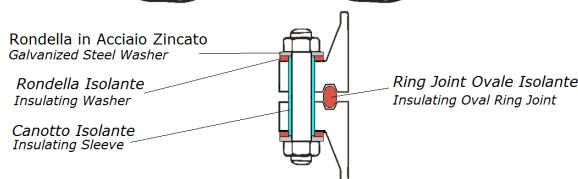
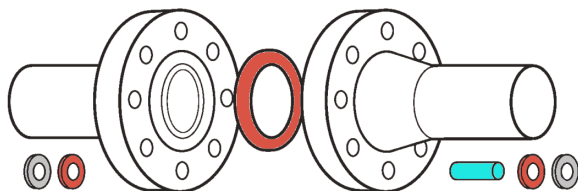

D TYPE - RING JOINT GASKET (RJ)

Insulation kit suitable for Ring Joint Flanges. Ring Joint gasket is manufactured in insulation material (Bachelized Cloth, PTFE; NEMA G11)

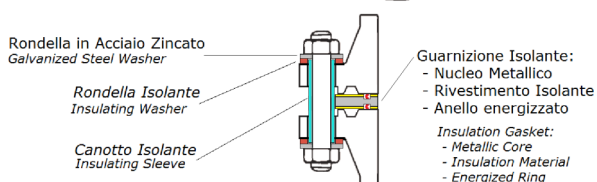
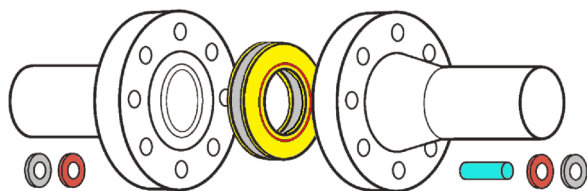

SPRING TYPE

Thanks to lip seal, the gasket requires a low tightening load; acting on the gasket the fluid pressure increase the specific load.

Our Flink Spring are manufactured by

- an Aisi 316 core gasket in which we install two energized lip seal (PTFE/Elgiloy) and covered with an insulating layer (Phenolic resin: NEMA LI-1 G11) on both sides
- One insulation sleeve for each bolts (NEMA G10 or PTFE for T series)
- Couple of insulating washer for each bolt
- Couple of metallic washer for each



Electrically Insulation kits

For Flange ASME B 16.5 Class 150lb & 300lb

Prod. Code: 340

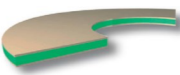
GASKET DATA										
	NEMA G11	RIGID MICA	NEOPRENE	EPDM	NBR	FKM	PTFE	EXPANDED PTFE	MTF 2310	TFV 1104
MAXIMUM PRESSURE (bar)	—	—	17	17	17	17	50	200	80	60
OPERATING THERMAL RANGE (°C)	-50 +180	— +500	-20 +90	-30 +120	-20 +95	-20 +200	-200 +260	-240 +260	-200 +260	-200 +260
DIELECTRIC STRENGTH (Kw/mm)	11,5	> 20	16 to 26	20 to 40	17	15 to 20	20 to 40	20 to 30	15	10
pH RANGE	—	—	—	—	—	—	0 to 14	0 to 14	0 to 14	0 to 14

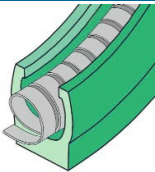
	U.M.	ENERGIZED LIP SEAL PTFE / ELGILOY
MAXIMUM TEMPERATURE	°C	-200 to +260
MAXIMUM PRESSURE	Bar	For vacuum up to 800*
RANGE pH	—	0 to 14

* For higher pressures contact the technical department.

INSULATING SLEEVES and WASHERS DATA							
	NEMA G10	NEMA FR4	NEMA G11	NEMA FR5	NEMA G11 H	BAKELIZED CLOTH	RIGID MICA
DENSITY (g/cm ³)	1,95	1,90	1,90	1,95	1,90	1,35	2,1
THERMAL CLASSIFICATION (Maximum Temperature)	B (°C 130)	B (°C 130)	F (°C 155)	H (°C 180)	H (°C 180)	E (°C 120)	H (°C 180)
WATER ABSORPTION mm 3 (%)	0,4	0,4	0,4	0,2	0,4	3,0	0,8
SELF EXTINGUISHING	NO	YES (V0)	NO	YES (V0)	NO	HB	YES (V0)
TENSILE STRENGTH (MPa)	250	300	300	450	300	70	—
COMPRESSIVE STRENGTH (MPa)	250	300	300	400	300	160	400
DIELECTRIC STRENGTH (Kw)	30	35	35	60	35	10	—
DIELECTRIC STRENGTH (Kw/mm)	15	10	11,5	15	11,5	2	20